

REVISIONS						
SHEET	ZONE	REV.	ECO	DESCRIPTION	DATE	APPROVED
1	ALL	A	50253	UPDATE DWG TO CURRENT FORMAT & STANDARDS	10/30/2018	HRC
ALL	ALL	B	50307	CONVERT DYED TO MOLDED BLACK	1/10/2020	HRC

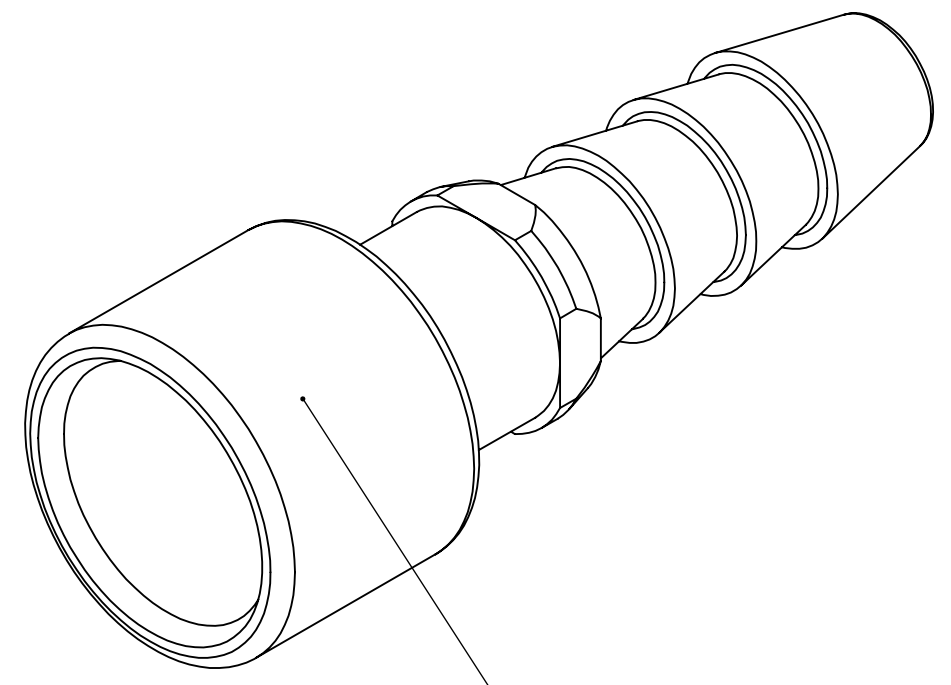

**SOCKET
(ACETAL)**

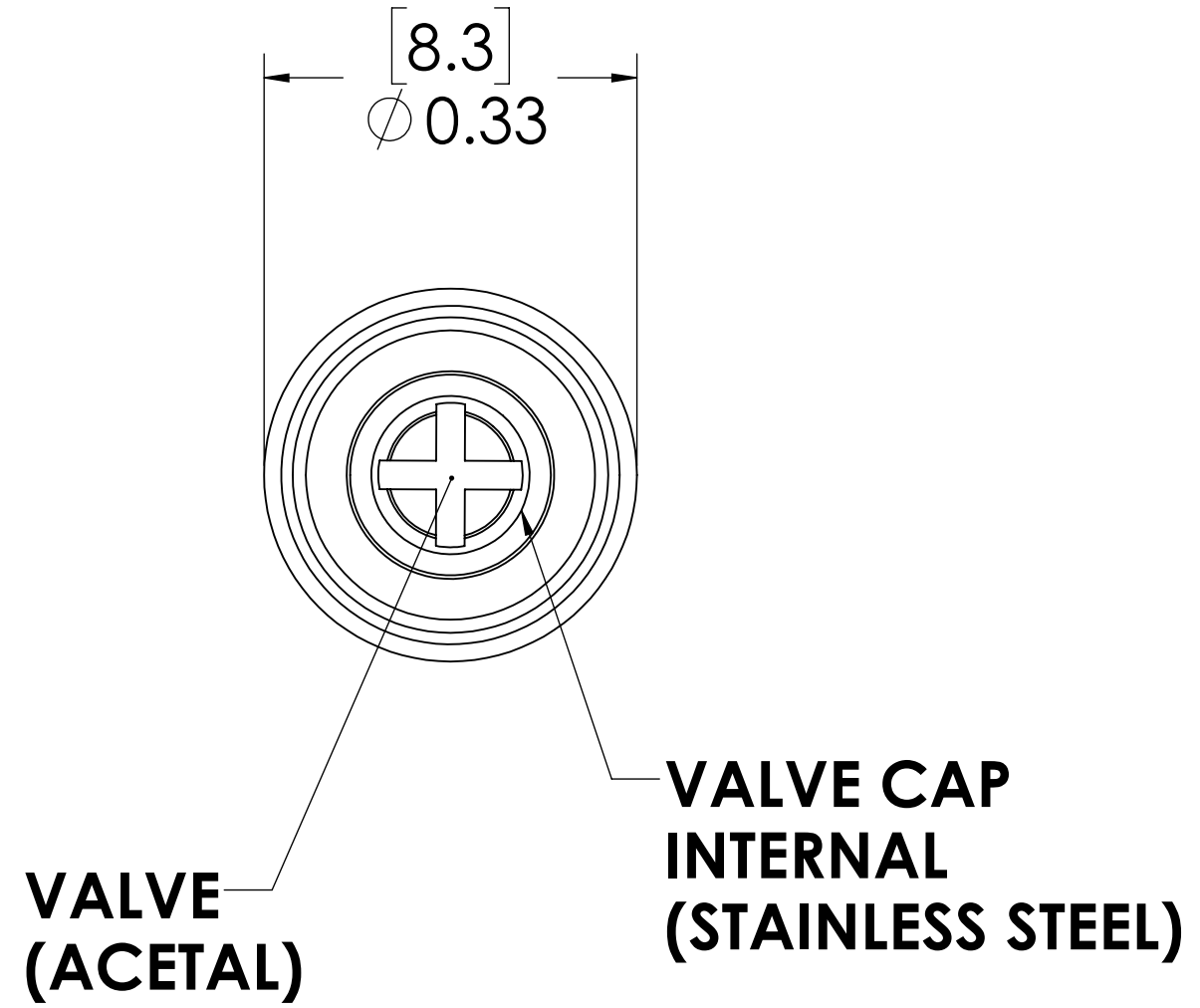

**VALVE
(ACETAL)**

**VALVE CAP
INTERNAL
(STAINLESS STEEL)**

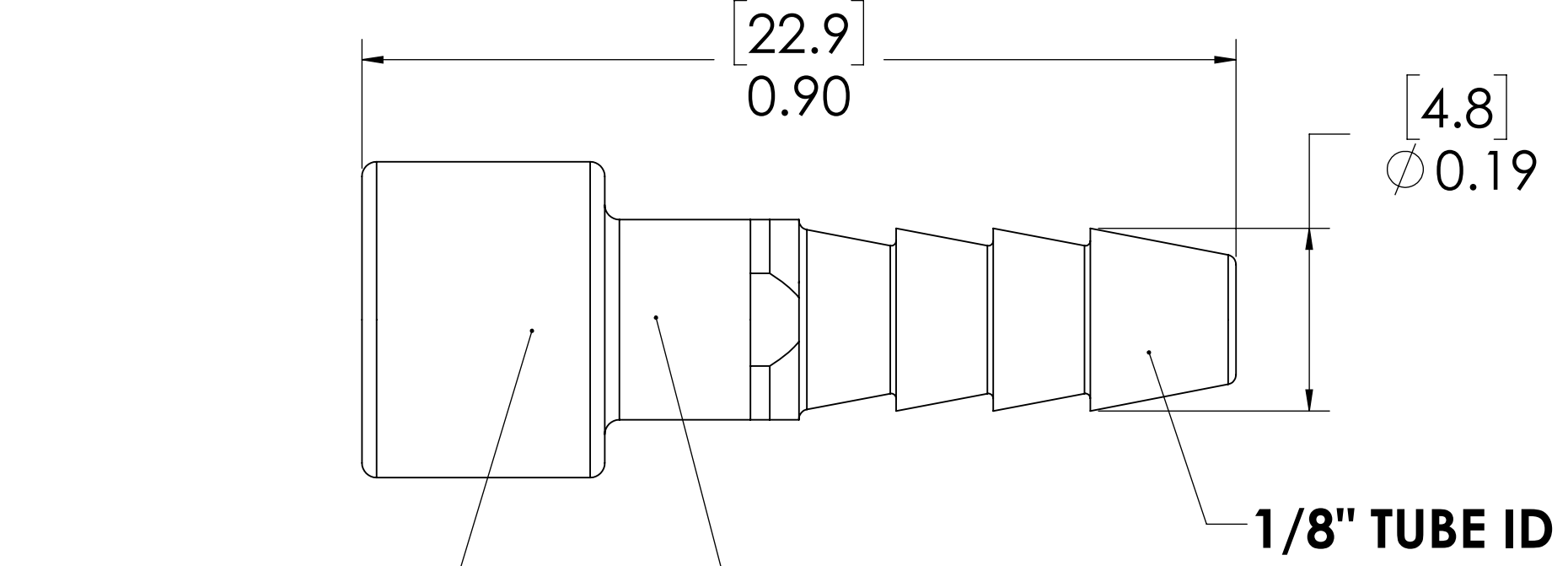

**VALVE SPRING
INTERNAL
(STAINLESS STEEL)**

**VALVE O-RING
INTERNAL
(BUNA-N)**

1/8" TUBE ID

- NOTES:**
- MATERIAL: ACETAL
 - COLOR: BLACK
 - O-RING MATERIAL: BUNA-N
 - O-RINGS LUBRICATED WITH FOOD GRADE SILICONE OIL, 350 CST.

FOR REFERENCE ONLY

<small>UNLESS OTHERWISE SPECIFIED: DIMENSIONS ARE IN INCHES TOLERANCES: FRACTIONAL ± 1/32 ANGULAR: MACH ± 0.5 BEND ± 2 ONE PLACE DECIMAL ± 0.1 TWO PLACE DECIMAL ± 0.01 THREE PLACE DECIMAL ± 0.005 TWO PLACE DUAL (mm) [± 0.12]</small>	DRAWN	LMP	5/4/2018	 LinkTech 10AC Series Inline Socket, Valved, 1/8" HB, No Sleeve, Black
	CHECKED	HRC	5/4/2018	
	ENG APPR.	HRC	10/30/18	
	MFG APPR.	BDB	10/30/18	
PRODUCTION	LS	10/30/18		PART NO: 10ACV-SB2-02NSBLK DESCRIPTION: LinkTech 10AC Series Inline Socket, Valved, 1/8" HB, No Sleeve, Black
<small>PROPRIETARY AND CONFIDENTIAL THE INFORMATION CONTAINED IN THIS DRAWING IS THE SOLE PROPERTY OF LINKTECH LLC. ANY REPRODUCTION OR DISCLOSURE IN PART OR AS A WHOLE WITHOUT THE WRITTEN PERMISSION OF LINKTECH LLC IS STRICTLY PROHIBITED.</small>				COMMENTS:
SIZE C DWG. NO. 10AC100093 REV B	SCALE: NTS	WEIGHT:	SHEET 1 OF 1	